

PROCEDURE FOR INDUSTRIAL CARTRIDGE KIT ASSEMBLY AND ROTATION CHANGE



The direction of rotation is determined from the shaft end of the pump
 Right hand rotation is clockwise
 Left hand rotation is counter clockwise

Use the following steps for assembly and rotation changes

- Scribe the cartridge kit to facilitate reassembly see drawing # 1
- Remove screws
- Open cartridge kit and rotate Ring / Rotor / Vanes as an assembly

Note the following during assembly

- Rotor has an arrow engraved to ensure proper positioning for right and left hand rotation see drawing # 3
- All vanes should have an intravane that slides freely in the intravane slot
- Vanes should when installed in the rotor slide freely
- Install vanes with sharp edge leading in the direction of rotation see drawing # 3
- Ring has an arrow engraved to ensure proper positioning for right and left hand rotation see drawing # 2

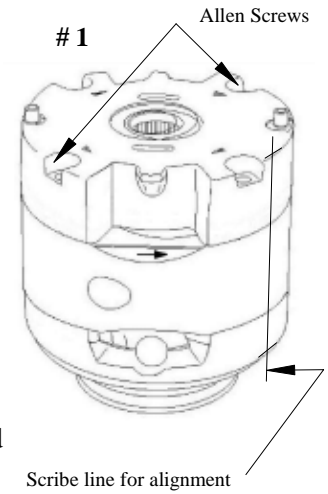

2

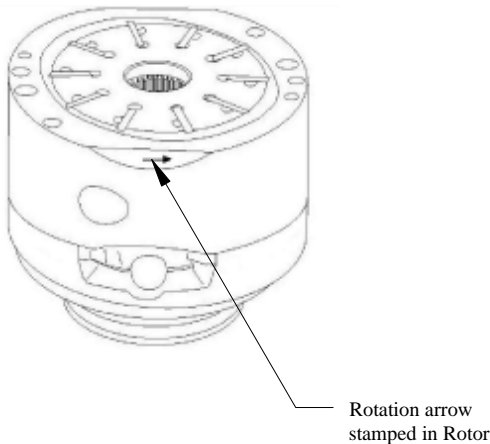

3

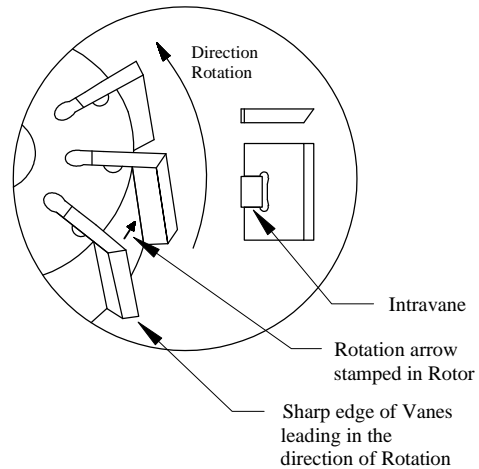

Use scribe mark to align support plates - ring

Install socket screws with minimum torque and align cartridge kit by sliding pump casting onto the cartridge until each part is centered. Gently remove pump casting and tighten screws to the table # 1 torque. Install cartridge in casting to assure proper alignment if the assembly binds in the casting repeat above procedure.

After cartridge kit is assembled use your finger to move the rotor which should move freely back and forth within the cartridge

Bolt Torques **table #1**

Pump SE	Cartridge Kit (in lb.)
20 V	30
25 V	40
35 V	90
45 V	100