

IFP PVB5/PVB6 PISTON PUMPS

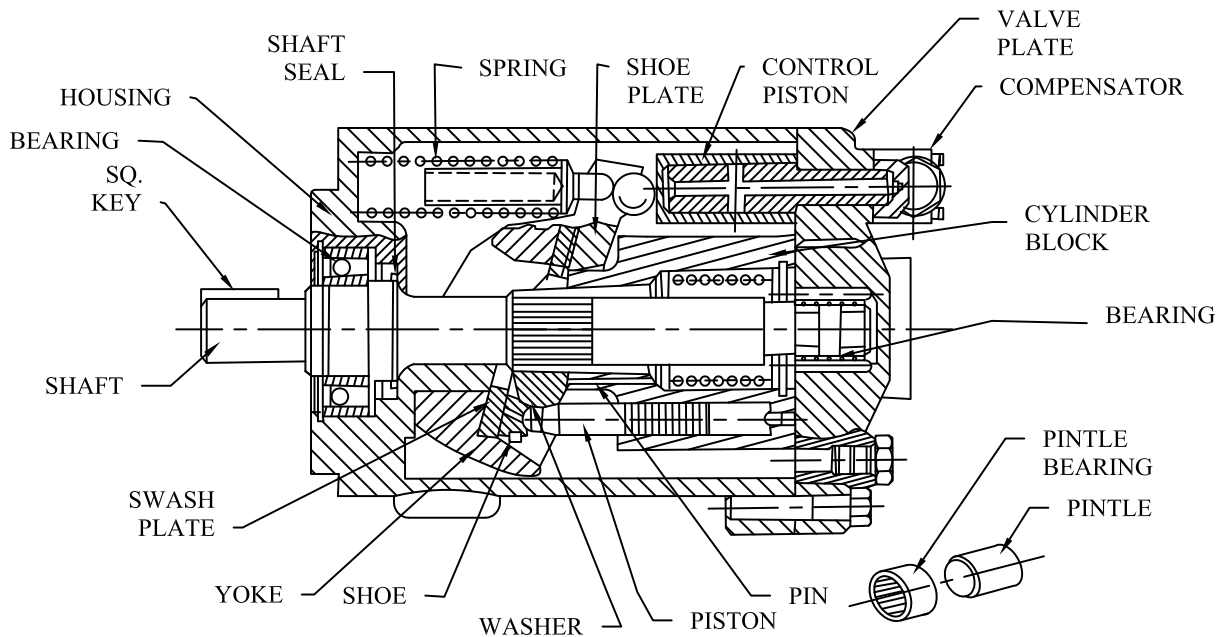

SERVICE PARTS INFORMATION



PART #	DESCRIPTION	PART #	DESCRIPTION	PART #	DESCRIPTION
875775N	ROT GROUP PVB5	919191N	SEAL KIT	317572N	PINTLE BEARING
875773N	ROT GROUP PVB6	237014N *	SEAL	273409N	LIFT LIMITER
319245N Δ	SW. PLATE	279615N *	GASKET	165385N	RET. RING
942229N Δ	PISTON PVB5(9)	244956N *	COMP. GASKET	241579N	PISTON
942230N Δ	PISTON PVB6(9)	308334N	HOUSING	241924N	PISTON ROD
274249N Δ	SHOE PLATE	231557N	YOKE	185638N	RET. RING
275485N Δ	SPHER. WASHER	373132N	YOKE SPRING	039465N	PLATE BEARING
274956N Δ	WASHER	373131N	SEAT	942223N	RH PLATE PVB5/6
248203N Δ	PINS(3)	319243N	PINTLE	942224N	LH PLATE PVB5/6
274670N Δ	CYL BLOCK PVB5	283233N	BEARING SHAFT	942158N C	COMPENSATOR
315148N Δ	CYL BLOCK PVB6	266162N	STD KEYED SHAFT	942159N CM	COMPENSATOR
275474N Δ	THRUST WASHER	142843N	SHAFT KEY	942480N CG	COMPENSATOR
274787N Δ	SPRING CYL. BL.	190362N	RETAINER	924059N CVP	COMPENSATOR
				942188N	MAX STOP (CCW)
				942189N	MAX STOP (CW)

* INCLUDED IN SEAL KIT

Δ INCLUDED IN ROTATING GROUP

Bolt Torque 150-181 lb.in

Note:

- Optional side ports, thru-shaft available.
- Optional compensator/controls available. (see page B1.7)
- Optional maximum flow adjustment available. (see page B1.8)
- Optional foot bracket

Filtration

For satisfactory service life use full flow filtration to provide fluid which ISO cleanliness code 16/13.