

# IFP 25MN/35MN/45MN/50MN VANE MOTOR INSTALLATION/DIMENSIONS

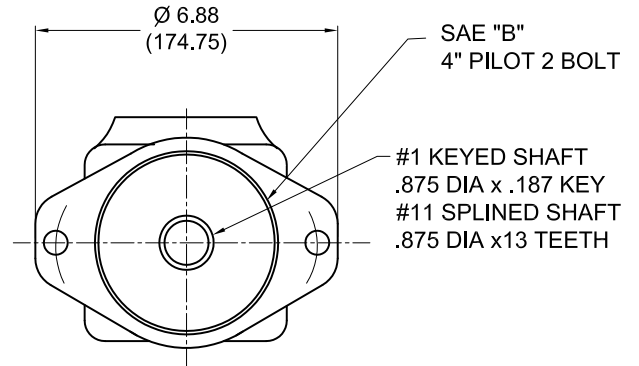

## 25MN

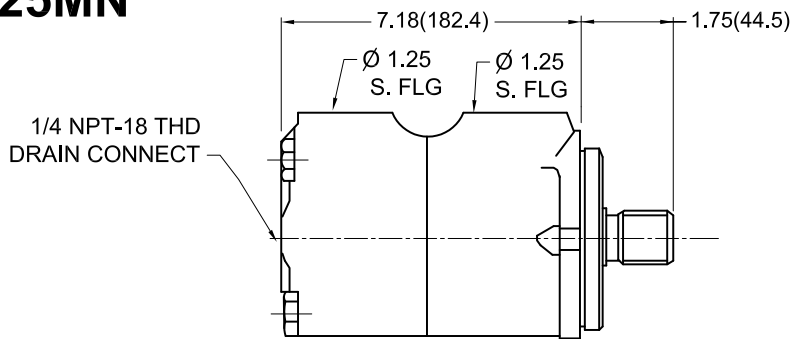

## 35MN

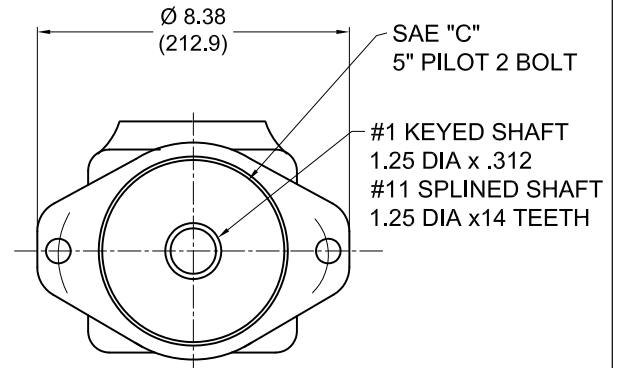
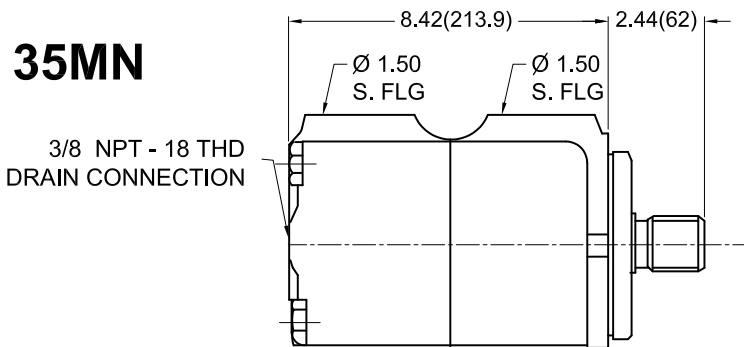

## 45MN

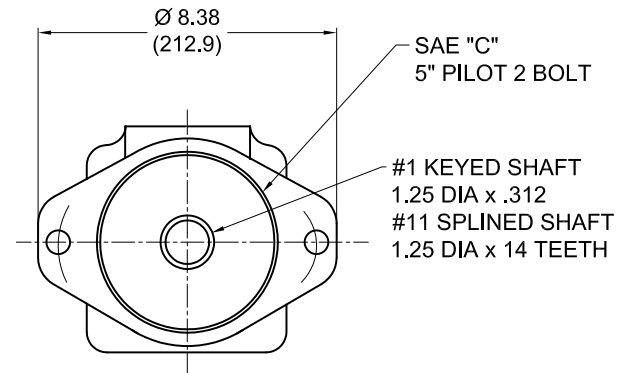
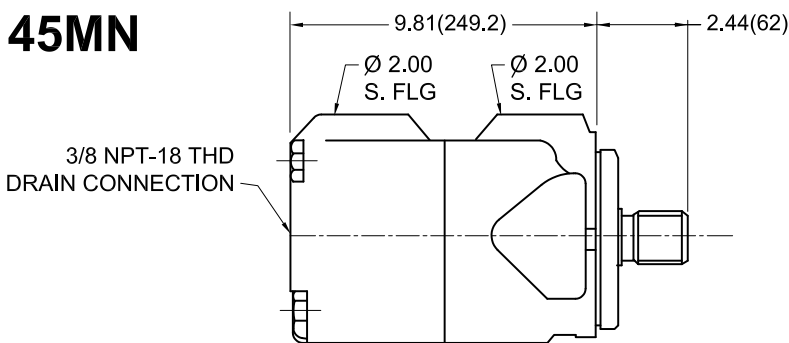

## 50MN

