

IFP BMG HIGH TORQUE LOW SPEED MOTORS



TIMING PROCEDURE

STANDARD ROTATION

Motor rotation will be as shown in Figure #1 when the following timing procedure is used

- Position tooth slot#1 on shaft assembly in line with tooth slot#3 highest point of geroter

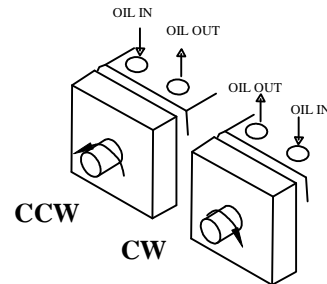
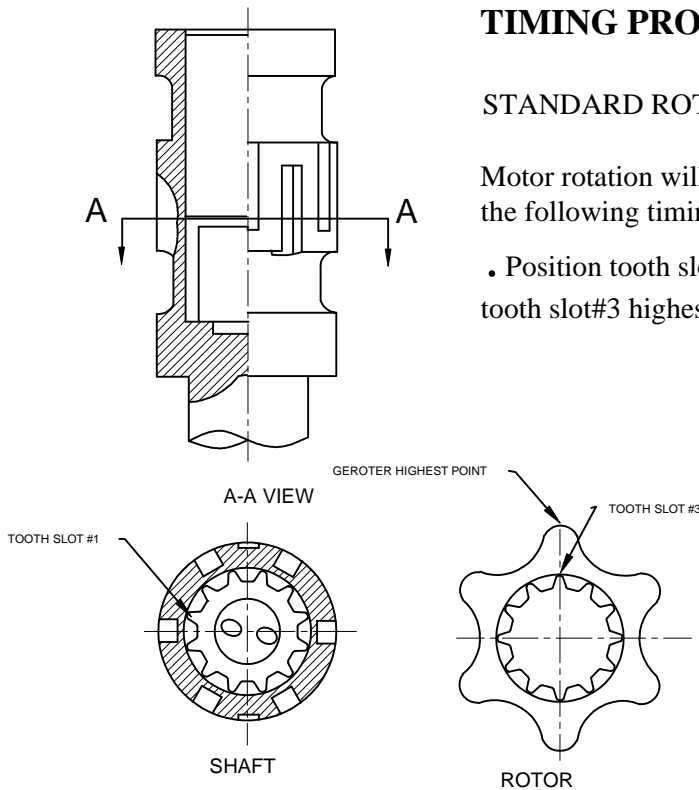

Figure #1

When timing is orientated as shown

TIMING PROCEDURE

REVERSE ROTATION

Motor rotation will be as shown in Figure #2 when the following timing procedure is used

- Position tooth slot#2 on shaft assembly in line with tooth slot#3 highest point of geroter

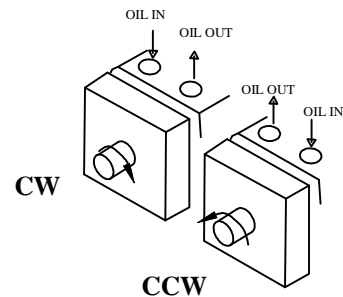
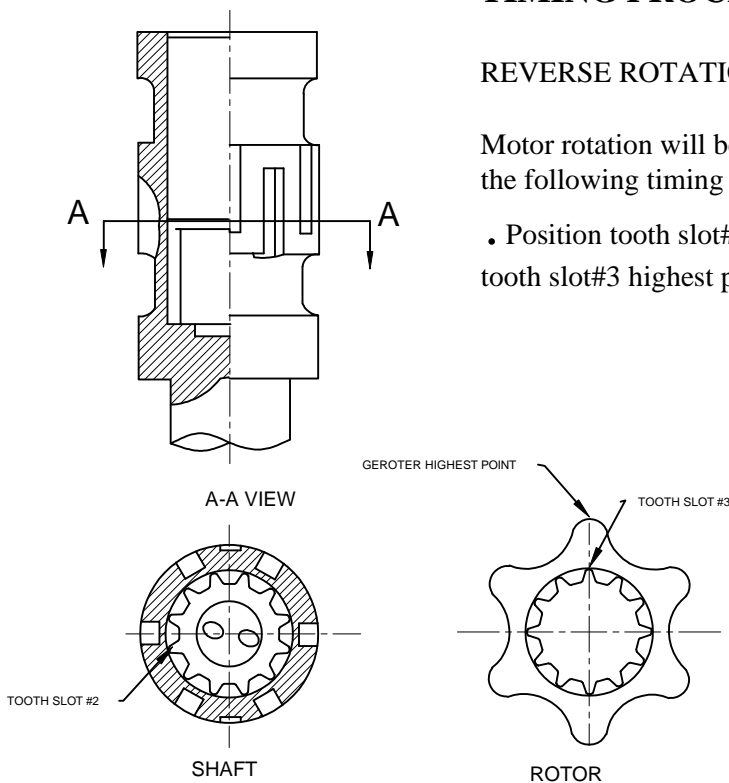

Figure #2

When timing is orientated as shown