

# IFP BML HIGH TORQUE LOW SPEED MOTORS



## High Performance in an economical package

International BML motors provide high output torque from an efficient compact design. Motors are available with displacements from 3.1 - 22.6 c.i.r (51.3 -370 c.c.r) BML motors provide smooth low speed performance while maintaining high output torque. Motors can be connected together in series, or parallel and there shaft seal design allow the motor to withstand high back pressures without an external case drain. When operated within there rated conditions these motors provide a long trouble free service life.

### Features:

- \* High volumetric efficiency
- \* High starting torque
- \* Series - Parallel installation
- \* Compact design



### Model code

**BML - 30 - 2 - S K**

Series                      Model                      Mounting                      Porting                      Shaft

Code	Mounting
2	SAE A 2 Bolt Flange
4	Square 4 Bolt Flange
6	SAE A Bolt Flange (Magneto mount)

Code	Porting
S	7/8-14 SAE
P	1/2" NPT
B	1/2" BSP
F	Flange Mount

Code	Shaft
K	1" Keyed
S	1" 6 tooth Spline

Other shafts available  
See page: D1.3

Model		BML 30	BML 49	BML 61	BML 76	BML 98	BML 122	BML 152	BML 192	BML 244
<b>Displacement</b> in3/rev (cm3/rev)		3.1 (51.3)	4.9 (80.6.)	6.1 (100.8)	7.6 (124.9)	9.6 (157.2)	12.2 (199.2)	15.4 (252)	19.2 (314.5)	22.6 (370)
<b>Speed</b> RPM	Continuous	755	750	600	475	375	300	240	190	160
	Intermittent	970	940	750	600	470	375	300	240	200
<b>Torque</b> in-lb (Nm)	Continuous	885 (100)	1681 (190)	2124 (240)	2584 (292)	3212 (363)	3168 (358)	3115 (352)	3186 (360)	3717 (420)
	Intermittent	1115 (126)	1947 (220)	2478 (280)	3009 (340)	3805 (430)	3965 (448)	4159 (470)	4159 (470)	4850 (548)
<b>Power</b> H.P.(kW)	Continuous	10.3 (7.7)	20.1 (15)	20.1 (15)	18.8 (14)	18.8 (14)	14.8 (11)	12.1 (9)	9.4 (7)	11.5 (8.6)
	Intermittent	13.0 (9.7)	22.8 (17)	22.8 (17)	21.4 (16)	21.4 (16)	18.8 (14)	16.1 (12)	12.1 (9)	16.1 (12)
<b>Pressure</b> PSI (Mpa)	Continuous	2030 (14)	2537 (17.5)	2537 (17.5)	2537 (17.5)	2392 (16.5)	1885 (13)	1595 (11)	1595 (11)	1450 (10)
	Intermittent	2537 (17.5)	2900 (20)	2900 (20)	2900 (20)	2900 (20)	2537 (17.5)	2030 (14)	1810 (12.5)	1667 (11.5)
<b>Flow</b> GPM (LPM)	Continuous	12 (45)	12 (45)	16 (60)	16 (60)	16 (60)	16 (60)	16 (60)	16 (60)	16 (60)
	Intermittent	13.2 (50)	20 (75)	20 (75)	20 (75)	20 (75)	20 (75)	20 (75)	20 (75)	20 (75)
<b>Weight</b> Lbs (kg)		14.8 (6.7)	15.2 (6.9)	15.3 (7.0)	15.8 (7.2)	16.5 (7.5)	17.6 (8.0)	18.7 (8.5)	19.8 (9.0)	20.5 (9.3)

**Continuous operation:** Motor may be run continuously at these ratings

**Intermittent operation:** Motor May be run 10% of every minute at these ratings

**Intermittent speed & intermittent pressure must not occur simultaneously**

**Recommended fluids:** Premium quality, anti-wear type hydraulic oil

**Recommended Temperature:** 180 F { 82 C }

**Recommended filtration:** per ISO Cleanliness code level 18/13

# IFP BML HIGH / TORQUE LOW / SPEED MOTORS

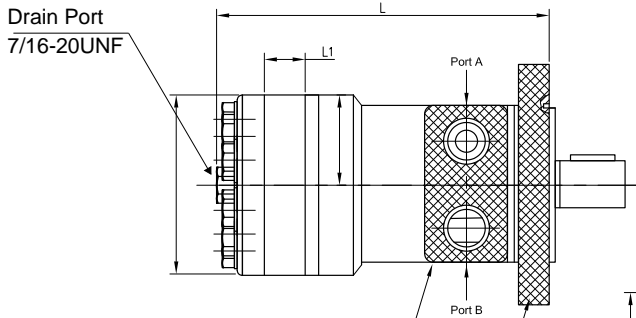

## Mounting

**Code: 2**  
**SAE-A 2 Bolt**

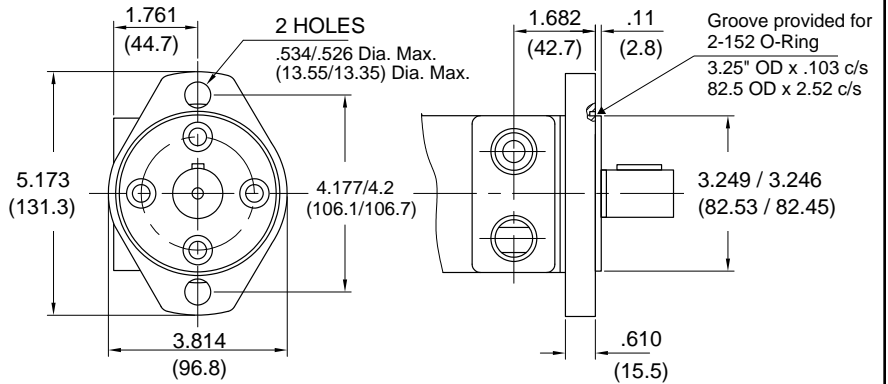

**Porting: Threaded**

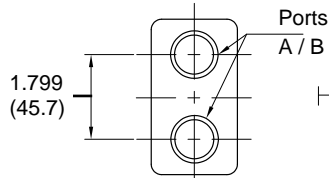

**Code: S** = A / B ports 7/8-14 UNF  
**Code: P** = A / B ports 1/2" NPTF  
**Code: B** = A / B ports 1/2" BSPT

**Porting: Flanged**

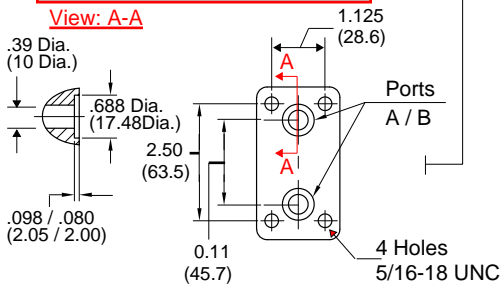

**Code: 6**  
**Magneto Mount 4 Bolt**

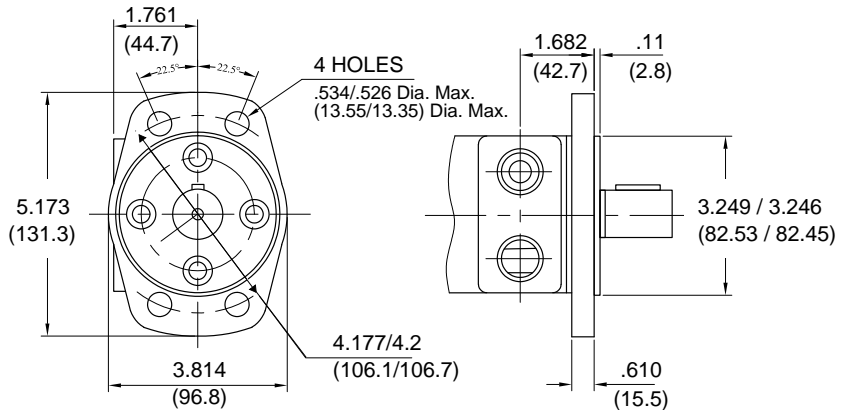

**Code: 4**  
**Square Mount 4 Bolt**

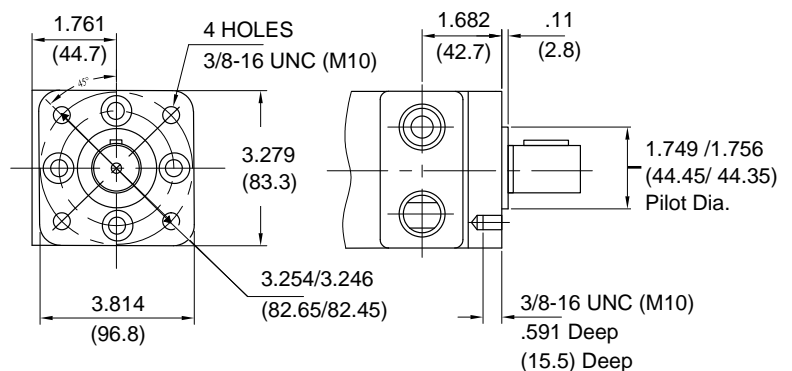

Code	Dimension: L	Dimension: L1
BML30	5.66 (144)	.39 (10)
BML49	5.90 (150)	.63 (16)
BML61	6.06 (154)	.79 (20)
BML76	6.26 (159)	.98 (25)
BML98	6.52 (155.5)	1.24 (31.5)
BML122	6.85 (174)	1.57 (40)
BML152	7.24 (184)	1.97 (50)
BML192	7.71 (196)	2.44 (62)
BML244	8.19 (208)	2.91 (74)

# IFP BML MOTOR DRIVE SHAFT SPECIFICATIONS



**Code: K \*\* Standard shaft \*\***  
**1 Inch Dia. Straight with Woodruff Key**

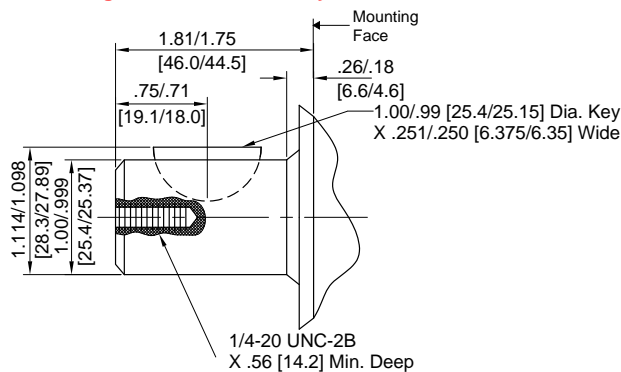

**Code: D \*\* Special Order \*\***  
**7/8 Inch Dia. Straight Shaft with Key**

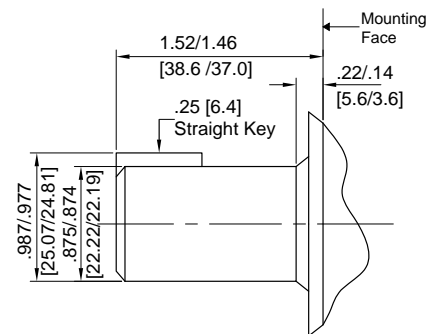

**Code: A \*\* Special Order \*\***  
**1 Inch Dia. Straight with Key**

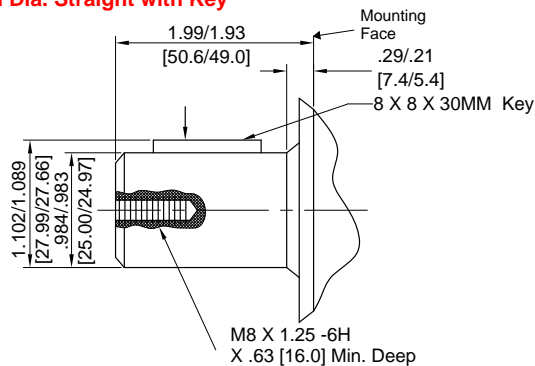

**Code: T2 \*\* Special Order \*\***  
**1 Inch Dia. Tapered Shaft With Woodruff Key & Nut**

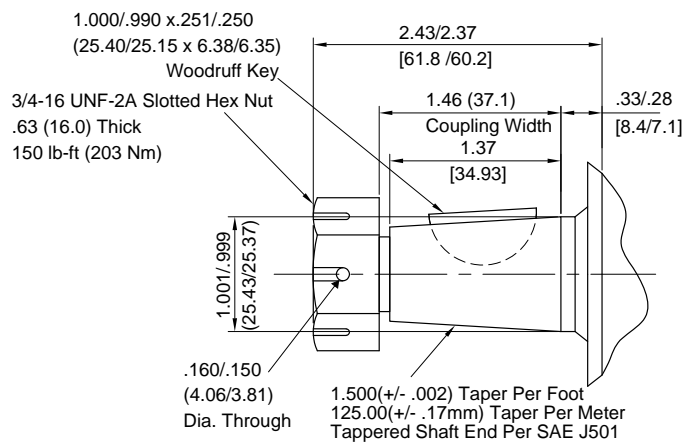

**Code: H1 \*\* Special Order \*\***  
**1 Inch Dia. Straight Shaft with .315 Crosshole**

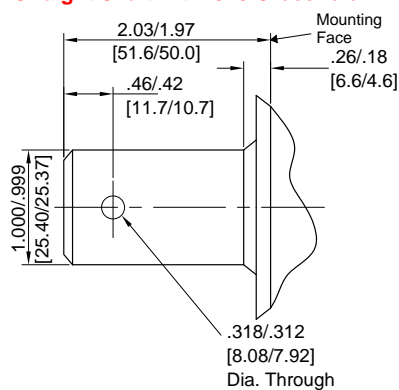

**Code: H \*\* Special Order \*\***  
**1 Inch Dia. Straight Shaft with .406 Crosshole**

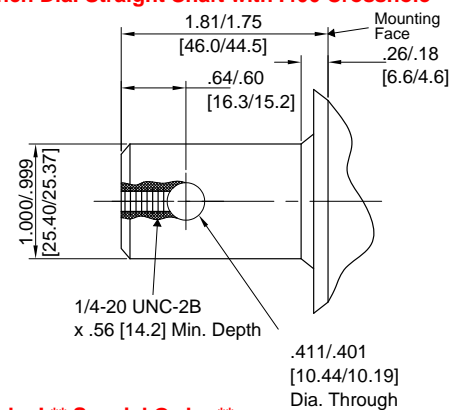

**Code: S \*\* Special Order \*\***  
**SAE 6 B 1" Dia. Splined Shaft**

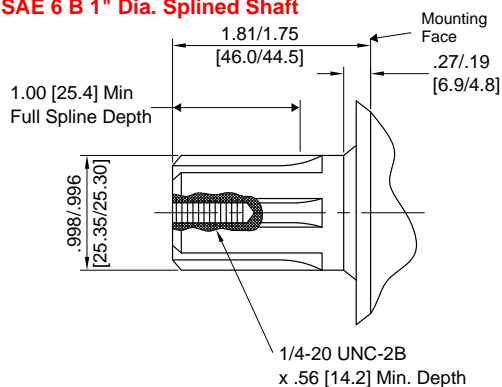

**Code: I \*\* Special Order \*\***  
**7/8" Dia. 13 tooth SAE-B Splined Shaft**

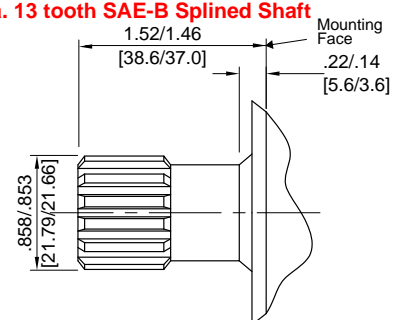

# IFP BML MOTOR PERFORMANCE DATA



**BML30:** 3.1 in3/rev {51.3 cm3/rev}

**BML49:** 4.9 in3/rev {80.6 cm3/rev}

Flow GPM {LPM}	Pressure- PSI {Mpa}								max. Cont.	max. Int.
	725 {5}	1015 {7}	1305 {9}	1450 {10}	1740 {12}	2030 {14}	2320 {16}	2537 {17.5}		
1.3 {5}	310 {35}	398 {45}	539 {61}	592 {67}	681 {77}	778 {88}				
2.6 {10}	318 {36}	407 {46}	548 {62}	610 {69}	708 {80}	840 {95}	955 {108}	1062 {120}		
4.0 {15}	309 {35}	433 {49}	557 {63}	646 {73}	778 {88}	885 {100}	964 {109}	1088 {123}		
5.3 {20}	305 {34.5}	415 {47}	539 {61}	610 {69}	734 {83}	850 {96}	964 {109}	1115 {126}		
6.6 {25}	301 {34}	398 {45}	539 {61}	610 {69}	716 {81}	849 {96}	964 {109}	1115 {126}		
7.9 {30}	292 {33}	389 {44}	531 {60}	592 {67}	708 {80}	840 {95}	955 {108}	1115 {126}		
9.2 {35}	274 {31}	371 {42}	522 {59}	584 {66}	708 {80}	823 {93}	947 {107}	1097 {124}		
Max. Cont. 10.6 {40}	265 {30}	362 {41}	513 {58}	584 {66}	699 {79}	814 {92}	938 {106}	1079 {122}		
Max. Int. 11.9 {45}	261 {29.5}	354 {40}	504 {57}	575 {65}	690 {78}	796 {90}	929 {105}	1070 {121}		

Flow GPM {LPM}	Pressure- PSI {Mpa}								max. Cont.	max. Int.
	725 {5}	1015 {7}	1305 {9}	1450 {10}	1740 {12}	2030 {14}	2320 {16}	2537 {17.5}		
2.6 {10}	486 {55}	681 {77}	867 {98}	947 {107}	1150 {130}	1318 {149}	1504 {170}	1593 {180}		
5.3 {20}	442 {50}	722 {81.6}	929 {105}	1044 {118}	1168 {132}	1416 {160}	1575 {178}	1672 {189}		
5.3 {30}	424 {48}	654 {74}	858 {97}	1008 {114}	1159 {131}	1327 {150}	1584 {179}	1681 {190}		
10.6 {40}	398 {45}	628 {71}	840 {95}	929 {105}	1132 {128}	1318 {149}	1566 {177}	1663 {188}		
13.2 {50}	371 {42}	619 {70}	796 {90}	867 {98}	1106 {125}	1301 {147}	1513 {171}	1655 {187}		
15.9 {60}	336 {38}	557 {63}	752 {85}	840 {95}	1044 {118}	1256 {142}	1495 {169}	1637 {185}		
Max. Cont. 18.5 {70}	318 {36}	513 {58}	708 {80}	787 {89}	991 {112}	1230 {139}	1451 {164}	1584 {179}		
Max. Int. 19.8 {75}	256 {29}	495 {56}	681 {77}	752 {85}	973 {110}	1177 {133}	1421 {161}	1566 {177}		

Torque: lb-in {Nm}  
Speed: RPM

**BML61:** 6.1 in3/rev {100.8 cm3/rev}

**BML76:** 7.6 in3/rev {124.9 cm3/rev}

Flow GPM {LPM}	Pressure- PSI {Mpa}								max. Cont.	max. Int.
	725 {5}	1015 {7}	1305 {9}	1450 {10}	1740 {12}	2030 {14}	2320 {16}	2537 {17.5}		
2.6 {10}	619 {70}	885 {100}	1079 {122}	1221 {138}	1407 {159}	1610 {182}	1858 {210}	1964 {222}		
5.3 {20}	601 {68}	840 {95}	1088 {123}	1265 {143}	1460 {165}	1770 {200}	1956 {221}	2106 {238}		
5.3 {30}	548 {62}	831 {94}	1070 {121}	1239 {140}	1451 {164}	1717 {194}	1947 {220}	2124 {240}		
10.6 {40}	522 {59}	778 {88}	1053 {119}	1185 {134}	1424 {161}	1699 {192}	1929 {218}	2106 {238}		
13.2 {50}	486 {55}	734 {83}	1035 {117}	1106 {125}	1389 {157}	1637 {185}	1920 {217}	2079 {235}		
15.9 {60}	424 {48}	699 {79}	973 {110}	1053 {119}	1345 {152}	1593 {180}	1894 {214}	2062 {233}		
Max. Cont. 18.5 {70}	380 {43}	619 {70}	885 {100}	991 {112}	1256 {142}	1504 {170}	1778 {201}	2026 {229}		
Max. Int. 19.8 {75}	345 {39}	557 {63}	858 {105}	929 {105}	1239 {140}	1478 {167}	1743 {197}	2009 {227}		

Flow GPM {LPM}	Pressure- PSI {Mpa}								max. Cont.	max. Int.
	725 {5}	1015 {7}	1305 {9}	1450 {10}	1740 {12}	2030 {14}	2320 {16}	2537 {17.5}		
2.6 {10}	796 {90}	1079 {122}	1416 {160}	1531 {173}	1814 {205}	2097 {237}	2283 {258}	2389 {270}		
5.3 {20}	752 {85}	1044 {118}	1407 {159}	1522 {172}	1840 {208}	2212 {250}	2460 {278}	2584 {292}		
5.3 {30}	725 {82}	947 {107}	1398 {158}	1451 {164}	1823 {206}	2133 {241}	2451 {277}	2575 {291}		
10.6 {40}	699 {79}	929 {105}	1327 {150}	1424 {161}	1805 {204}	2106 {238}	2433 {275}	2557 {289}		
13.2 {50}	663 {75}	849 {96}	1283 {145}	1416 {160}	1752 {198}	2088 {236}	2318 {262}	2495 {282}		
15.9 {60}	548 {62}	840 {95}	1230 {139}	1398 {158}	1619 {183}	1964 {222}	2248 {254}	2469 {279}		
Max. Cont. 18.5 {70}	522 {59}	734 {83}	1106 {125}	1327 {150}	1575 {178}	1876 {212}	2212 {250}	2318 {262}		
Max. Int. 19.8 {75}	495 {56}	708 {80}	1079 {122}	1283 {145}	1522 {172}	1814 {205}	2168 {245}	2310 {261}		

Torque: lb-in {Nm}  
Speed: RPM

Continuous -   
Intermittent -

# IFF BML MOTOR PERFORMANCE DATA



**BML98:** 9.6 in3/rev {157.2 cm3/rev}

**BML122:** 12.2 in3/rev {199.2 cm3/rev}

		Pressure- PSI {Mpa}					max. Cont.	max. Int.	
		725 {5}	1015 {7}	1305 {9}	1450 {10}	1740 {12}	2030 {14}	2320 {16}	2537 {17.5}
Flow GPM {LPM}	2.6 {10}	1017 {115}	1416 {160}	1796 {203}	1947 {220}	2301 {260}	2655 {300}	3009 {340}	3203 {362}
	5.3 {20}	1008 {114}	1416 {160}	1814 {205}	2035 {230}	2345 {265}	2832 {320}	3142 {355}	3363 {380}
	5.3 {30}	929 {105}	1398 {158}	1787 {202}	1956 {221}	2310 {261}	2699 {305}	3044 {344}	3345 {378}
	10.6 {40}	885 {100}	1283 {145}	1734 {196}	1929 {218}	2274 {257}	2646 {299}	3009 {340}	3310 {374}
	13.2 {50}	796 {90}	1239 {140}	1681 {190}	1849 {209}	2212 {250}	2610 {295}	2973 {336}	3239 {366}
	15.9 {60}	743 {84}	1203 {136}	1593 {180}	1761 {199}	1977 {240}	2478 {286}	2832 {330}	3186 {360}
Max. Cont.	18.5 {70}	575 {65}	1062 {120}	1451 {164}	1593 {180}	1973 {223}	2478 {280}	2832 {320}	3097 {350}
Max. Int.	19.8 {75}	522 {59}	1026 {116}	1398 {158}	1548 {175}	1947 {220}	2407 {272}	2779 {314}	3026 {342}

		Pressure- PSI {Mpa}					max. Cont.	max. Int.
		725 {5}	1015 {7}	1305 {9}	1522 {10.5}	1740 {12}	2030 {14}	2537 {17.5}
Flow GPM {LPM}	2.6 {10}	1309 {148}	1814 {205}	2256 {255}	2566 {290}	2894 {327}	3274 {370}	3912 {442}
	5.3 {20}	1239 {140}	1787 {202}	2212 {250}	2858 {323}	2920 {330}	3637 {411}	3965 {448}
	5.3 {30}	1150 {130}	1708 {193}	2133 {241}	2717 {307}	2876 {325}	3336 {377}	3938 {445}
	10.6 {40}	1106 {125}	1646 {186}	2053 {232}	2699 {305}	2770 {313}	3451 {390}	3858 {436}
	13.2 {50}	1062 {120}	1566 {177}	1991 {225}	2610 {295}	2699 {305}	3380 {382}	3779 {427}
	15.9 {60}	973 {110}	1469 {166}	1956 {221}	2522 {285}	2584 {292}	3292 {372}	3708 {419}
Max. Cont.	18.5 {70}	867 {98}	1327 {150}	1814 {205}	2159 {244}	2460 {278}	2929 {331}	3628 {410}
Max. Int.	19.8 {75}	752 {85}	1247 {141}	1761 {199}	2079 {235}	2371 {268}	2858 {323}	3540 {400}

Torque: lb-in {Nm}  
Speed: RPM

**BML152:** 15.4 in3/rev {252 cm3/rev}

		Pressure- PSI {Mpa}					max. Cont.	max. Int.	
		435 {3}	725 {5}	1015 {7}	1160 {8}	1450 {10}	1595 {11}	2030 {14}	2537 {17.5}
Flow GPM {LPM}	2.6 {10}	1017 {115}	1593 {180}	2221 {251}	2610 {295}	3097 {350}	3363 {380}	4159 {470}	4735 {535}
	5.3 {20}	973 {110}	1578 {178}	2230 {252}	2602 {294}	3115 {352}	3407 {385}	4159 {470}	4850 {548}
	5.3 {30}	885 {100}	1504 {170}	2194 {248}	2522 {285}	3080 {348}	3372 {381}	4150 {469}	4823 {545}
	10.6 {40}	805 {91}	1407 {159}	2053 {232}	2371 {268}	2938 {332}	3239 {366}	4071 {460}	4690 {530}
	13.2 {50}	716 {81}	1309 {148}	1911 {216}	2230 {252}	2832 {320}	3115 {352}	4009 {453}	4611 {521}
	15.9 {60}	663 {75}	1168 {132}	1778 {201}	2079 {235}	2699 {305}	3009 {340}	3832 {433}	4469 {505}
Max. Cont.	18.5 {70}	442 {50}	1035 {117}	1672 {189}	1947 {220}	2566 {290}	2832 {320}	3646 {412}	4381 {495}
Max. Int.	19.8 {75}	371 {42}	929 {105}	1593 {180}	1867 {211}	2487 {281}	2743 {310}	3584 {405}	4301 {486}

Continuous -   
Intermittent -

# IFP BML MOTOR PERFORMANCE DATA



**BML192:** 19.2 in<sup>3</sup>/rev {314.5 cm<sup>3</sup>/rev}

	Pressure- PSI {Mpa}							max.	max.	
	435	725	943	1160	1305	1885	1957	Cont.	Int.	
	{3}	{5}	{6.5}	{8}	{9}	{13}	{13.5}			
Flow GPM {LPM}	2.6 {10}	1194 {135}	1902 {215}	2469 {279}	3035 {343}	3389 {383}	4558 {515}	4867 {550}		
		<b>31</b>	<b>29</b>	<b>28</b>	<b>27</b>	<b>27</b>	<b>24</b>	<b>22</b>		
	5.3 {20}	1177 {133}	1911 {216}	2557 {289}	3088 {349}	3363 {380}	4496 {508}	4885 {552}		
		<b>62</b>	<b>61</b>	<b>60</b>	<b>58</b>	<b>57</b>	<b>52</b>	<b>50</b>		
	5.3 {30}	1106 {125}	1814 {205}	2433 {275}	3018 {341}	3319 {375}	4372 {494}	4805 {543}		
		<b>95</b>	<b>92</b>	<b>91</b>	<b>90</b>	<b>88</b>	<b>81</b>	<b>79</b>		
	10.6 {40}	1000 {113}	1725 {195}	2363 {267}	2964 {335}	3248 {367}	4292 {485}	4655 {526}		
		<b>123</b>	<b>121</b>	<b>120</b>	<b>118</b>	<b>117</b>	<b>106</b>	<b>104</b>		
13.2 {50}	814 {92}	1504 {170}	2239 {253}	2841 {321}	3115 {352}	4195 {474}	4522 {511}			
	<b>155</b>	<b>154</b>	<b>152</b>	<b>149</b>	<b>147</b>	<b>137</b>	<b>133</b>			
15.9 {60}	708 {80}	1416 {160}	2044 {231}	2699 {305}	2956 {334}	4053 {458}	4354 {492}			
	<b>190</b>	<b>187</b>	<b>193</b>	<b>179</b>	<b>176</b>	<b>163</b>	<b>157</b>			
Max. Cont. 18.5 {70}	504 {57}	1203 {136}	1902 {215}	2522 {285}	2832 {320}	3929 {444}	4248 {480}			
	<b>222</b>	<b>220</b>	<b>217</b>	<b>212</b>	<b>208</b>	<b>192</b>	<b>185</b>			
Max. Int. 19.8 {75}	486 {55}	1097 {124}	1814 {205}	2380 {269}	2726 {308}	3779 {427}	4150 {469}			
	<b>235</b>	<b>234</b>	<b>231</b>	<b>227</b>	<b>225</b>	<b>408</b>	<b>201</b>			

**BML244:** 22.6 in<sup>3</sup>/rev {370 cm<sup>3</sup>/rev}

	Pressure- PSI {Mpa}							max.	max.	
	435	725	943	1160	1305	1885	1957	Cont.	Int.	
	{3}	{5}	{6.5}	{8}	{9}	{13}	{13.5}			
Flow GPM {LPM}	2.6 {10}	1416 {160}	2389 {270}	3009 {340}	3717 {420}	4159 {470}	4867 {550}	5398 {610}		
		<b>26</b>	<b>25</b>	<b>24</b>	<b>22</b>	<b>21</b>	<b>19</b>	<b>17</b>		
	5.3 {20}	1407 {159}	2301 {260}	3009 {340}	3628 {410}	4159 {470}	4779 {540}	5354 {605}		
		<b>53</b>	<b>52</b>	<b>51</b>	<b>49</b>	<b>47</b>	<b>42</b>	<b>37</b>		
	5.3 {30}	1327 {150}	2256 {255}	2920 {330}	3540 {400}	3982 {450}	4690 {530}	5310 {600}		
		<b>79</b>	<b>78</b>	<b>77</b>	<b>75</b>	<b>73</b>	<b>67</b>	<b>60</b>		
	10.6 {40}	1194 {135}	2124 {240}	2743 {310}	3319 {375}	3805 {430}	4602 {520}	5221 {590}		
		<b>106</b>	<b>105</b>	<b>104</b>	<b>102</b>	<b>99</b>	<b>93</b>	<b>85</b>		
13.2 {50}	1062 {120}	2035 {230}	2610 {295}	3186 {360}	3717 {420}	4469 {505}	5044 {570}			
	<b>250</b>	<b>132</b>	<b>131</b>	<b>129</b>	<b>126</b>	<b>120</b>	<b>110</b>			
15.9 {60}	867 {98}	1858 {210}	2433 {275}	3009 {340}	3451 {390}	4336 {490}	4867 {550}			
	<b>159</b>	<b>158</b>	<b>157</b>	<b>155</b>	<b>153</b>	<b>147</b>	<b>135</b>			
Max. Cont. 18.5 {70}	663 {75}	1548 {175}	2212 {250}	2832 {320}	3274 {370}	4115 {465}	4690 {530}			
	<b>187</b>	<b>186</b>	<b>185</b>	<b>183</b>	<b>180</b>	<b>175</b>	<b>160</b>			
Max. Int. 19.8 {75}	575 {65}	1416 {160}	2035 {230}	2743 {310}	3186 {360}	3982 {450}	4558 {515}			
	<b>200</b>	<b>199</b>	<b>198</b>	<b>195</b>	<b>192</b>	<b>187</b>	<b>178</b>			

Torque: lb-in  
{Nm}  
Speed: RPM

Continuous -   
Intermittent -



**IFP HIGH TORQUE  
GEROTER / ROLLER MOTORS**  
Parts Service Information



**"BML SERIES"**

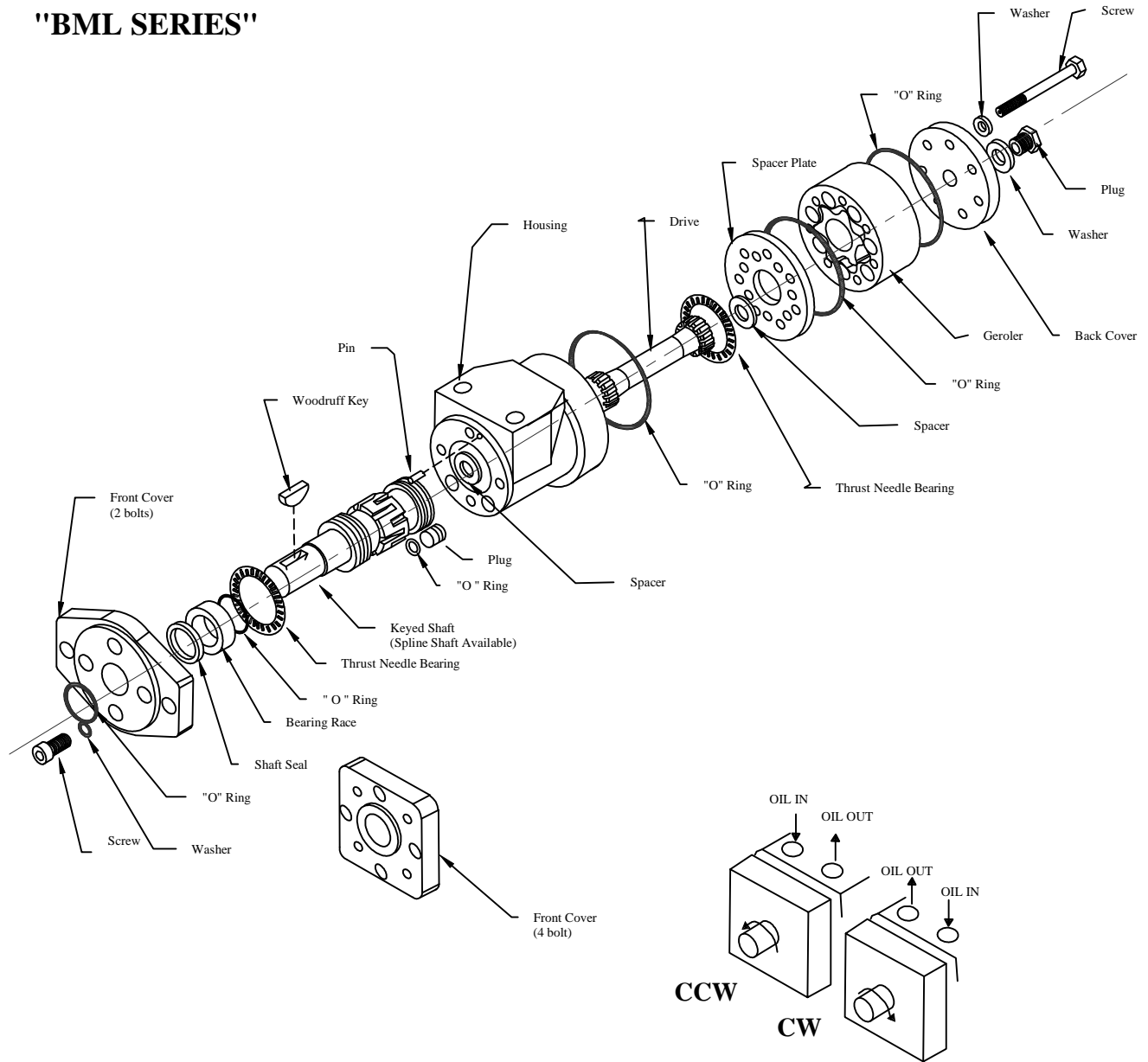

**MOTOR ROTATION**

FACTORY TIMING OF MOTOR WILL  
PRODUCE FOLLOWING ROTATIONS  
WHEN INLET AND OUTLET PORTS ARE  
ORIENTATED AS SHOW AS ABOVE  
DIAGRAMS

# CROSS REFERENCE BML GEROLER SERIES



\*INDICATES STANDARD STOCK UNITS  
STANDARD 4 BOLT/KEYED SHAFT(SPLINE SHAFTS AVAILABLE)

IFP MODEL	DISPL in/rev	CHARLYNN "S" MODEL	DISPL in/rev	DANFOSS "OMR" MODEL	DISPL in/rev	PORTS SIZE
BML030-4PK *BML030-4SK	3.0	103-1573 103-1570	3.6	151-2421 151-2341	3.1	1/2 NPTF SAE 7/8-14
BML049-4PK *BML049-4SK	4.9	103-1002 103-1010	4.5	151-2422 151-2342	4.9	1/2 NPTF SAE 7/8-14
BML061-4PK *BML061-4SK	6.1	103-1003 103-1011	5.9	151-2423 151-2343	6.1	1/2 NPTF SAE 7/8-14
BML076-4PK *BML076-4SK	7.6	103-1574 103-1571	7.3	151-2424 151-2344	7.7	1/2 NPTF SAE 7/8-14
		103-1575 103-1572	8.9	151-2224 151-2421		1/2 NPTF SAE 7/8-14
BML098-4PK *BML098-4SK	9.8	103-1004 103-1012	9.7	151-2425 151-2345	9.7	1/2 NPTF SAE 7/8-14
BML122-4PK *BML122-4SK	12.2	103-1005 103-1013	11.3	151-2426 151-2346	12.2	1/2 NPTF SAE 7/8-14
BML152-4PK *BML152-4SK	15.2	103-1006 103-1014	14.1	151-2427 151-2347	15.2	1/2 NPTF SAE 7/8-14
BML192-4PK *BML192-4SK	19.2	103-1007 103-1015	17.9	151-2428 151-2348	19.3	1/2 NPTF SAE 7/8-14
BML244-4PK *BML244-4SK	22.6	103-1008 103-1016	22.6	151-2429 151-2349	22.7	1/2 NPTF SAE 7/8-14

STANDARD 2 BOLT/KEYED SHAFT(SPLINE SHAFTS AVAILABLE)

IFP MODEL	DISPL in/rev	CHARLYNN "H" MODEL	DISPL in/rev	DANFOSS "OMR" MODEL	DISPL in/rev	PORTS SIZE
BML030-2PK *BML030-2SK	3.0	103-1540 103-1537	3.6	151-2084 151-2001	3.1	1/2 NPTF SAE 7/8-14
BML049-2PK *BML049-2SK	4.9	103-1026 103-1034	4.5	151-2082 151-2002	4.9	1/2 NPTF SAE 7/8-14
BML061-2PK *BML061-2SK	6.1	103-1027 103-1035	5.9	151-2083 151-2003	6.1	1/2 NPTF SAE 7/8-14
BML076-2PK *BML076-2SK	7.6	103-1541 103-1538	7.3	151-2084 151-2004	7.7	1/2 NPTF SAE 7/8-14
		103-1542 103-1539	8.9			1/2 NPTF SAE 7/8-14
BML098-2PK *BML098-2SK	9.8	103-1028 103-1036	9.7	151-2085 151-2005	9.7	1/2 NPTF SAE 7/8-14
BML122-2PK *BML122-2SK	12.2	103-1029 103-1037	11.3	151-2086 151-2006	12.2	1/2 NPTF SAE 7/8-14
BML152-2PK *BML152-2SK	15.2	103-1030 103-1038	14.1	151-2087 151-2007	15.2	1/2 NPTF SAE 7/8-14
BML192-2PK *BML192-2SK	19.2	103-1031 103-1039	17.9	151-2088 151-2008	19.3	1/2 NPTF SAE 7/8-14
BML244-2PK *BML244-2SK	22.6	103-1032 103-1040	22.6	151-2089 151-2009	22.7	1/2 NPTF SAE 7/8-14



# IFP BML HIGH TORQUE LOW SPEED MOTORS



## TIMING PROCEDURE

### STANDARD ROTATION

Motor rotation will be as shown in Figure #1 when the following timing procedure is used

- Position tooth slot#1 on shaft assembly in line with tooth slot#3 highest point of geroter

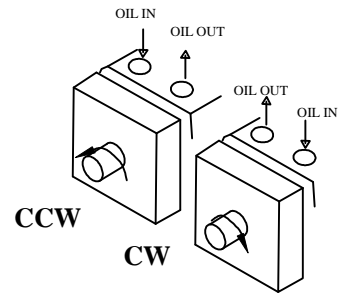
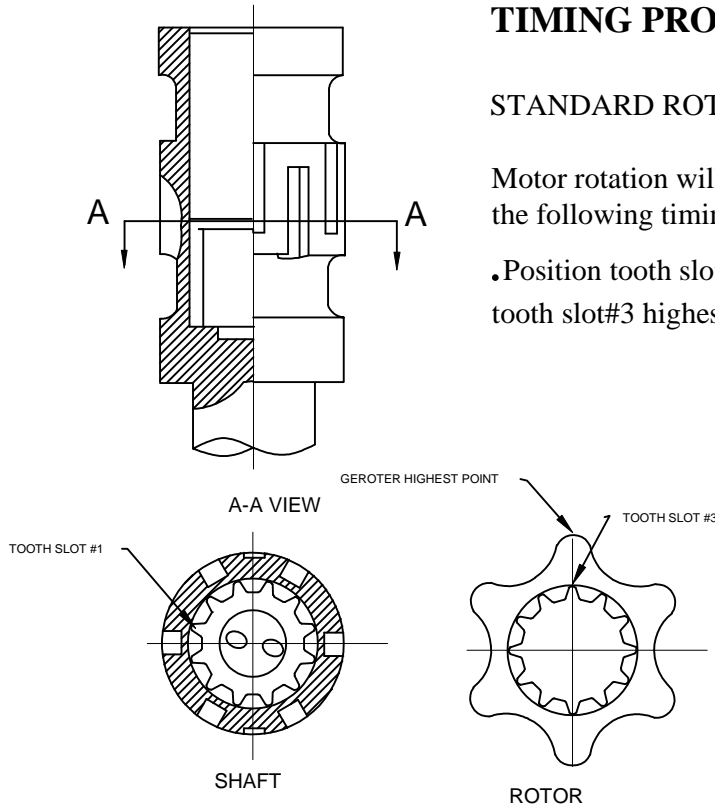

Figure #1  
When timing is orientated as shown

## TIMING PROCEDURE

### REVERSE ROTATION

Motor rotation will be as shown in Figure #2 when the following timing procedure is used

- Position tooth slot#2 on shaft assembly in line with tooth slot#3 highest point of geroter

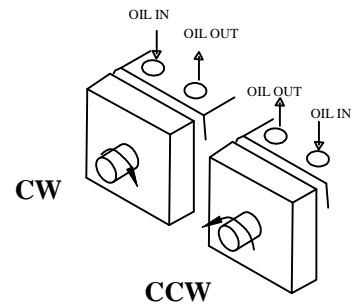
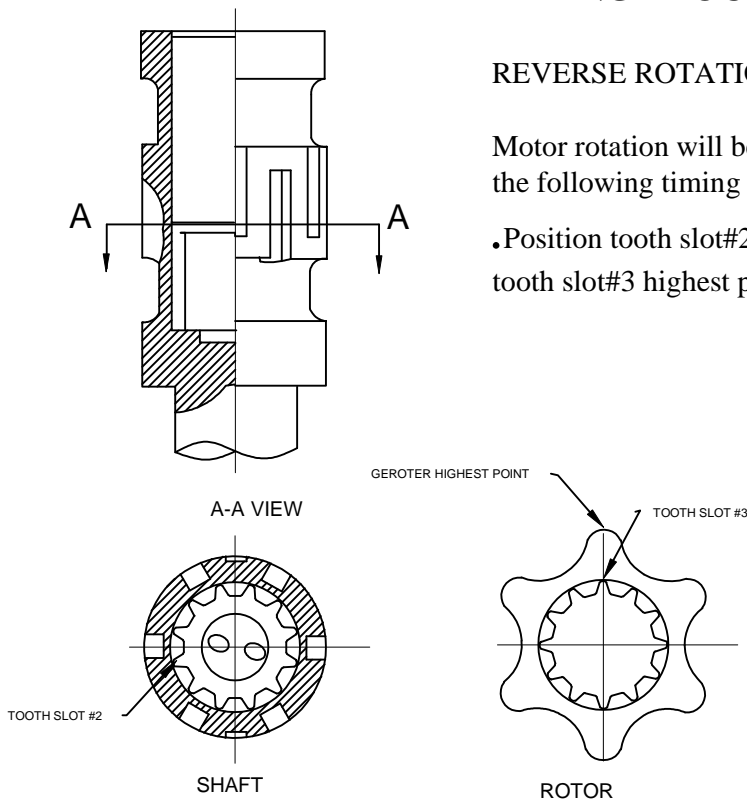

Figure #2  
When timing is orientated as shown