

# IFP MCB03 COUNTER BALANCE MODULE



## PERFORMANCE CURVES Viscosity (100-150 SUS)

MCB-03-A1-\*

Pressure Drop characteristic

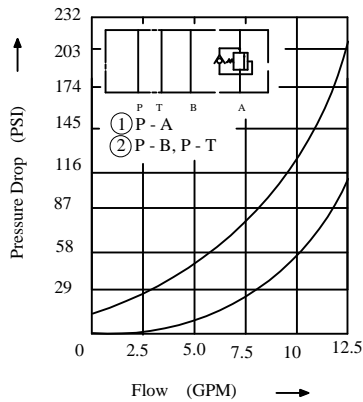

MCB-03-A1- \*  
B1

Pressure - Flow characteristic

————— PRESSURE INCREASE  
- - - - - PRESSURE DECREASE

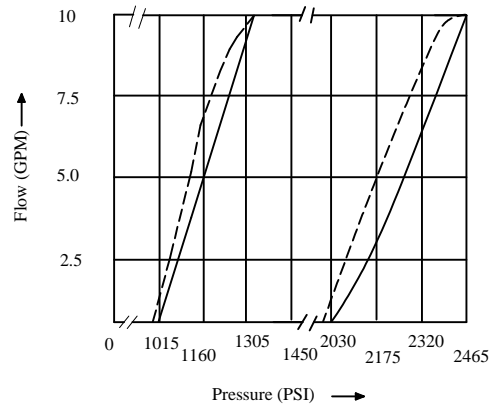

## CROSS SECTION DIAGRAM

MCB-03-A1-\*

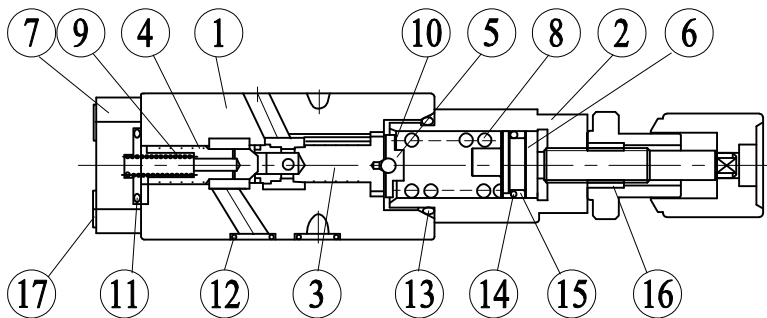

NO.	DESCRIPTION
1	BODY
2	RETAINER
3	SPOOL
4	POPPET
5	GUIDE
6	SCREW
7	COVER
8	SPRING
9	SPRING
10	BALL
11	O-RING
12	O-RING
13	O-RING
14	O-RING
15	BACK-UP RING
16	KNOB UNIT
17	SCREW

NO.	PARTS NAME	PARTS NO.	Q'TY
11	O-RING	P16, 90°	1
12	O-RING	P9, 90°	4
13	O-RING	P22, 90°	1
14	O-RING	P14, 70°	1