

IFP MCB05 COUNTER BALANCE MODULE



PERFORMANCE CURVES Viscosity (100-150 SUS)

MCB-05-A1-*

Pressure Drop characteristic

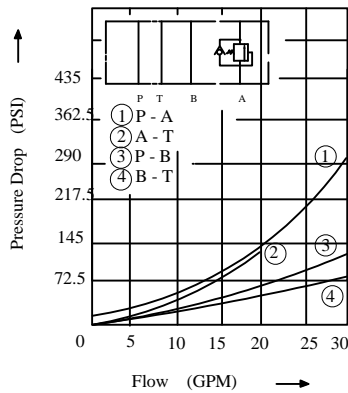

MCB-05-A1- *
B1

Pressure - Flow characteristic

————— PRESSURE INCREASE
----- PRESSURE DECREASE

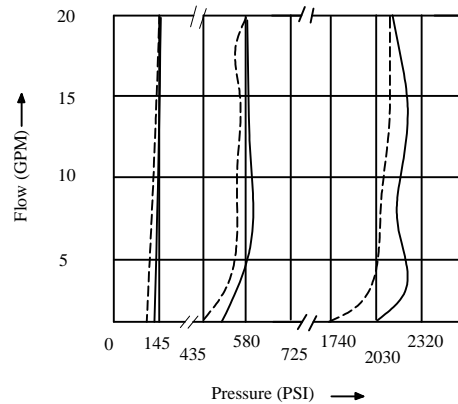

CROSS SECTION DIAGRAM

MCB-05-A1-1

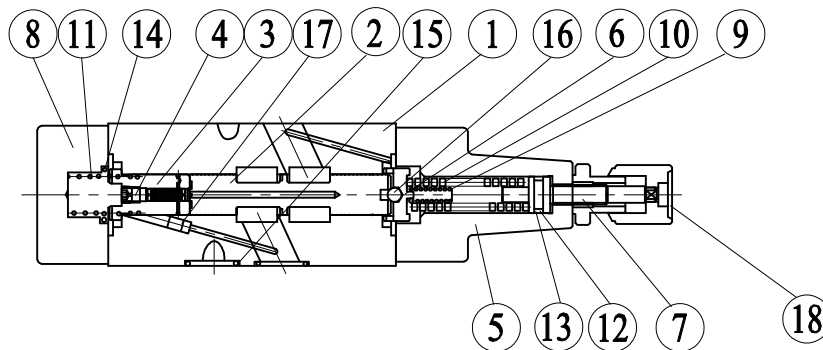

NO.	DESCRIPTION
1	BODY
2	SPOOL
3	SPOOL
4	SLEEVE
5	COVER
6	GUIDE
7	SCREW
8	COVER
9	SPRING
10	SPRING
11	O-RING
12	BACK-UP RING
13	O-RING
14	O-RING
15	O-RING
16	BALL
17	ORIFICE
18	PLATE

NO.	PARTS NAME	PARTS NO.	Q'TY
13	O-RING	P8, 70°	1
14	O-RING	P26, 90°	2
15	O-RING	AS-568-014	5