

# NBC TWO STAGE HYDRAULIC PUMPS DIMENSIONAL DATA

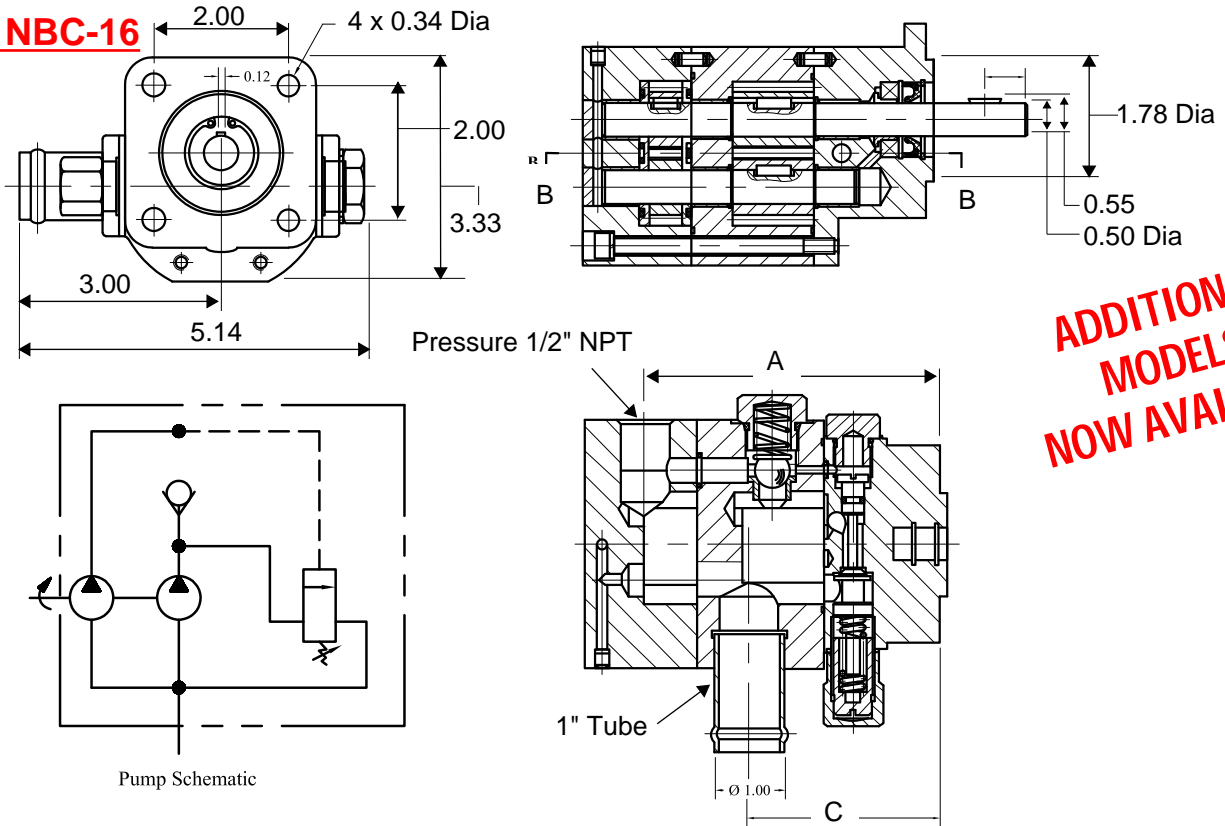

## NBC-8 to NBC-16



**ADDITIONAL  
MODELS  
NOW AVAILABLE**

MODEL	DIMENSIONS			MODEL	DIMENSIONS			MODEL	DIMENSIONS		
	A	B	C		A	B	C		A	B	C
NBC- 8	6.07	3.74	2.41	NBC- 10.5	6.54	4.08	2.74	NBC- 12.5	6.90	4.53	3.04
NBC- 8.5	6.21	3.90	2.41	NBC- 11	6.61	4.24	2.74	NBC- 13	7.00	4.53	3.04
NBC- 9	6.28	3.90	2.74	NBC-11.5	6.70	4.24	2.74	NBC- 13.5	7.09	4.53	3.04
NBC- 10	6.41	4.08	2.74	NBC- 12	6.70	4.37	3.04	NBC- 16	6.70	4.37	3.04

**REPLACES  
HALDEX  
BARNES**

## NBC-22 & NBC-28

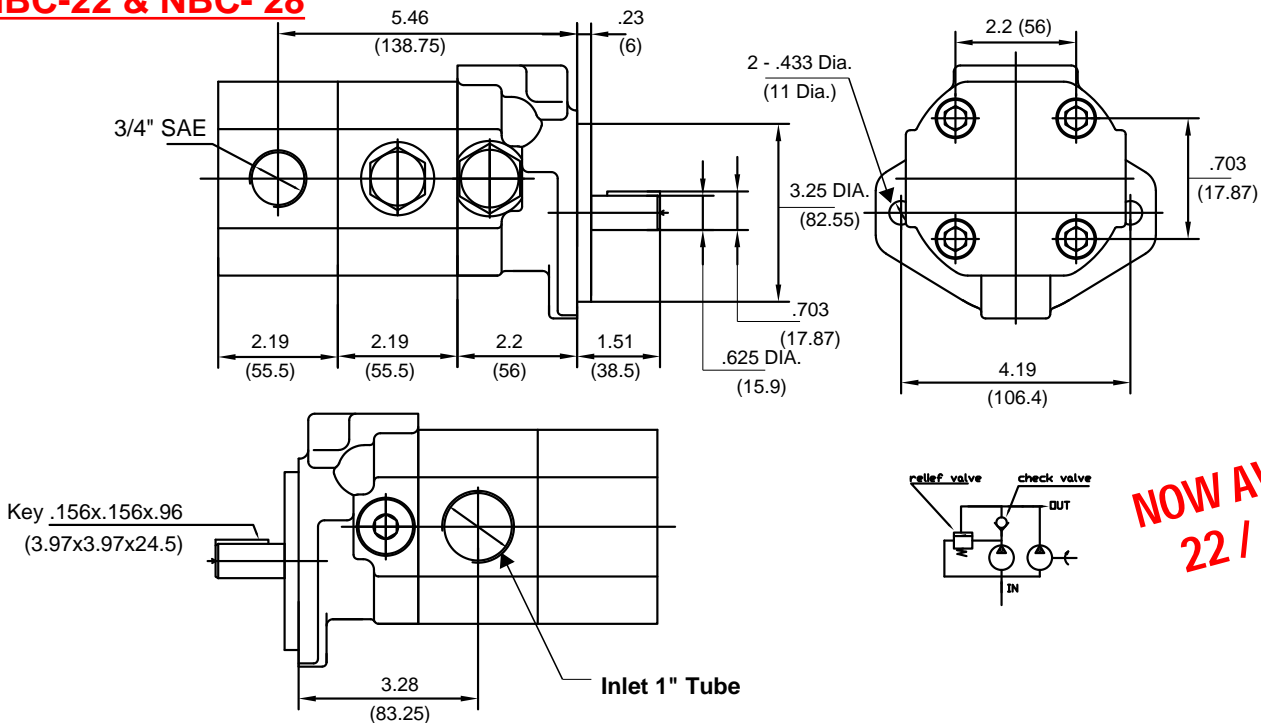

**NOW AVAILABLE  
22 / 28 GPM**