

IFP MFB10 PISTON MOTOR

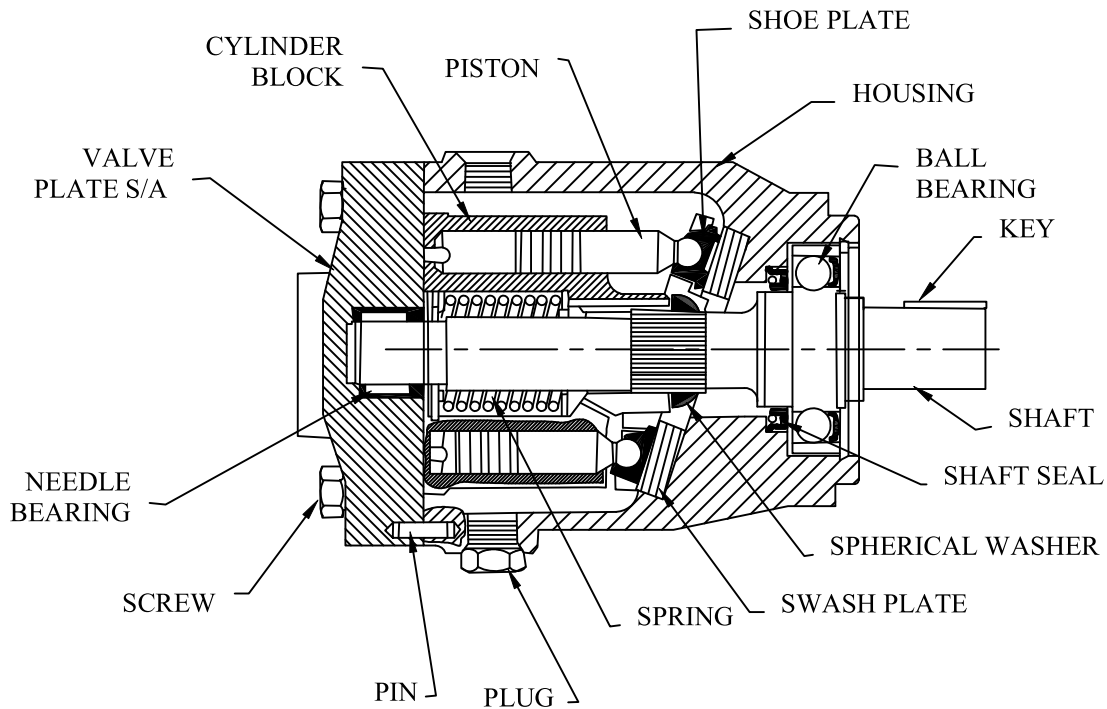

Service Parts Information



PART#	DESCRIPTION	PART#	DESCRIPTION	PART#	DESCRIPTION
938272	ROT GROUP MFB10	1276	SCREW(4 REQ'D)	154128 *	"O" RING
93509 Δ	RETAINING RING	938391	VALVE PLATE	343573 *	SHAFT SEAL
245223 Δ	LIFT LIM. WASHER	167237	PIN(2 REQ'D)	352432	VITON SHAFT SEAL
247294 Δ	SPRING	12016	NEEDLE BEARING	274382	SEAL RETAINER
241954 Δ	THRUST WASHER	425439 *	GASKET	261552	KEYED SHAFT
321703 Δ	CYLINDER BLOCK	942047 Δ	PISTON S/A KIT(9)	295729	SPLINE SHAFT
248811 Δ	PIN	239077 Δ	SWASH PLATE	284397	BEARING
423324 Δ	SPHERICAL WASHER	274831	HOUSING	119982	RETAINING RING
275961 Δ	SHOE PLATE	181728	PLUG	120428	RETAINING RING

Δ INCLUDE - ROTATION GROUP * INCLUDE - SEAL KIT (919240)
 SCREW (4 REQ.) 25-35 lb.ft.

WARNING:

Before starting fill motor case with system fluid through uppermost drain port. Housing must be kept full at all times to provide internal lubrication.