

IFP MFB5 PISTON MOTOR

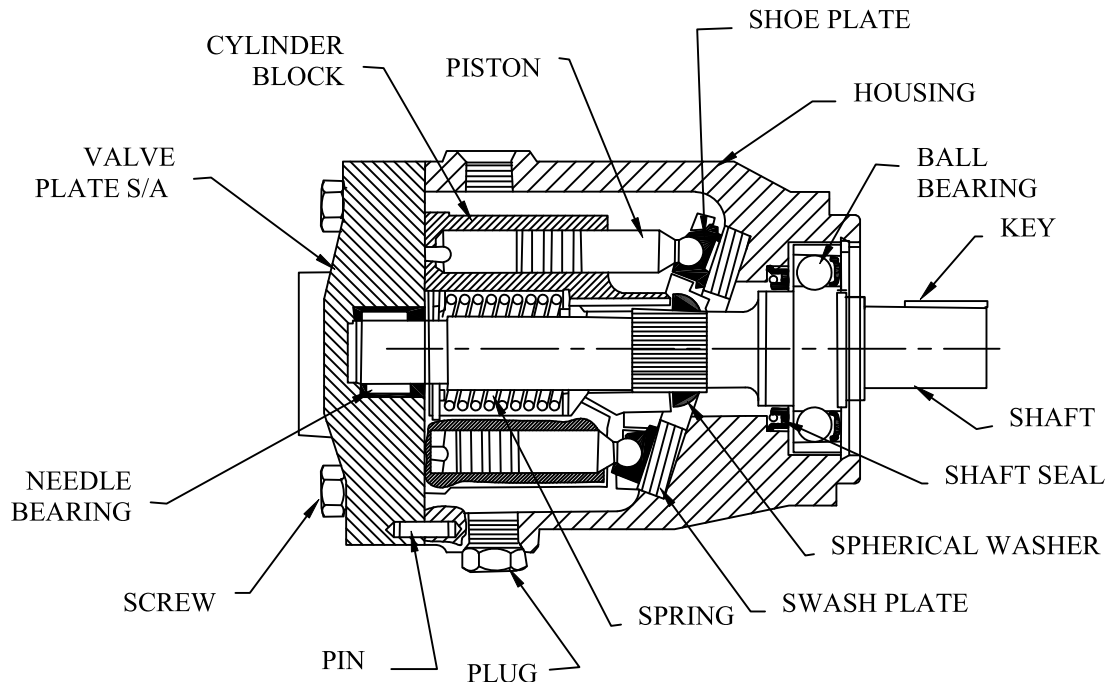

Service Parts Information



| PART# | DESCRIPTION |
|--------|--------------------|
| 875772 | ROT GROUP MFB5 |
| 165385 | △ RETAINING RING |
| 273409 | △ LIFT LIM. WASHER |
| 274787 | △ SPRING |
| 275474 | △ THRUST WASHER |
| 326181 | △ CYLINDER BLOCK |
| 248203 | △ PIN |
| 275485 | △ SPHERICAL WASHER |
| 274249 | △ SHOE PLATE |

| PART# | DESCRIPTION |
|--------|---------------------|
| 1253 | SCREW(4 REQ'D) |
| 938551 | VALVE PLATE |
| 167237 | PIN(2 REQ'D) |
| 39465 | NEEDLE BEARING |
| 279614 | * GASKET |
| 942229 | △ PISTON S/A KIT(9) |
| 319245 | △ SWASH PLATE |
| 323951 | HOUSING |
| 181728 | PLUG |

| PART# | DESCRIPTION |
|--------|------------------|
| 154128 | * "O" RING |
| 237014 | * SHAFT SEAL |
| 283687 | VITON SHAFT SEAL |
| 266160 | KEYED SHAFT |
| 295237 | SPLINE SHAFT |
| 283233 | BEARING |
| 98653 | RETAINING RING |
| 140356 | RETAINING RING |

△ INCLUDE - ROTATION GROUP * INCLUDE - SEAL KIT (919239)
 SCREW (4 REQ.) 25-35 lb.ft.

WARNING:

Before starting fill motor case with system fluid through uppermost drain port. Housing must be kept full at all times to provide internal lubrication.